

# KÄRCHER

makes a difference



## MULTIFUNCTIONAL, ENVIRONMENTALLY FRIENDLY, COMFORTABLE

The flexible all-rounder for your community

# PERFORMANCE, FLEXIBILITY, ENVIRONMENTAL PROTECTION.

The right machine at the right time in the right place. With Kärcher municipal machines you are optimally positioned to complete various daily tasks comfortably and efficiently.



# ROBUST, COMPACT, EFFICIENT.

Comfortable large cab  
with 360° panoramic view

Compact dimensions

State-of-the-art diesel technology\*

Efficient quick-change concept

Various attachment options

\*MIC 42 comply with the requirements of the  
exhaust emissions values of Tier 4 Final



Clever service concept

Innovative articulated steering

High payload and lifting force

Robust frame concept based on  
construction machines

True Track for 100% directional  
stability

Hydrostatic all-wheel drive with  
traction control

Our municipal machines impress  
heads of operations, drivers  
and workshop employees equally  
with up to 129 HP, innovative  
equipment details, a high level  
of comfort, the clever service

concept and their suitability  
for use in urban environmental  
zones. At any time of the year,  
in all weathers, for almost every  
municipal task.

# EVERYTHING THAT YOU NEED.

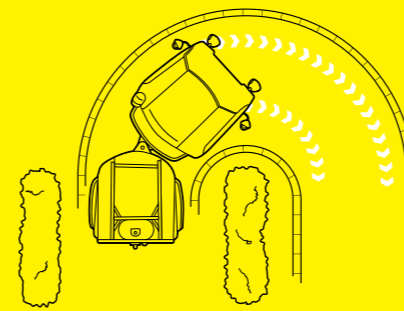

**More compact than you think** A certain level of compactness of the vehicle is essential for applications in inner city areas. This is why our municipal machines are as narrow, short and low as is technically possible. They have a low centre of gravity, and also the entry is deliberately kept very low.

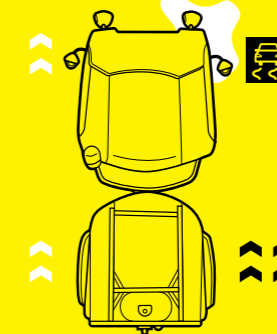

**Best traction all year round** Thanks to the permanent hydraulic all-wheel drive with traction control, optimal traction is guaranteed at any time. For extreme applications we also offer a differential lock as an option for some of our machines.

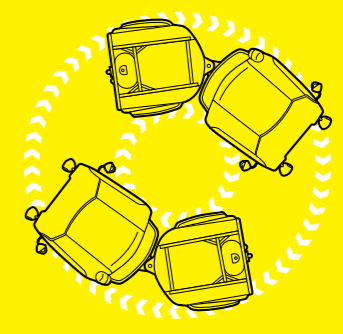

**Superb maneuverability** Our innovative articulated steering makes possible the almost impossible, thus permitting maximum flexibility. As a result, the rear vehicle always runs exactly in the track of the front vehicle. Thanks to this extreme maneuverability and the 100% directional stability, it is easy to drive around every obstacle and every kerb. Guaranteed without hitting anything.

**Municipal machines from Kärcher combine the benefits of multifunctional implement carriers and vacuum sweepers in one vehicle, and blend low dimensions with robust quality and a powerful drive with maximum environmental protection. The intuitive and logical operating concept as well as clearly structured and large cabs ensure plenty of comfort all year round, while the versatile quick-change system and quick access to all service components enable flexible and efficient working.**

**Robust. For tough day-to-day work** Derived from the world of construction machines, the support frame of our municipal machines consists of a thick-walled special structure, which confidently carries all vehicle components and implements. High axle loads also permit front mounting of heavy implements, which is crucial for winter service and garden maintenance.

**The comfort cab** Spacious cabs are not only much more comfortable for the operator, but thanks to the 360° all-round visibility they also improve the view of what's important, thus increasing safety. Our cabs are of course ROPS-certified and offer the best working conditions in hot and cold weather with their efficient ventilation systems as well as the optional air-conditioning system.

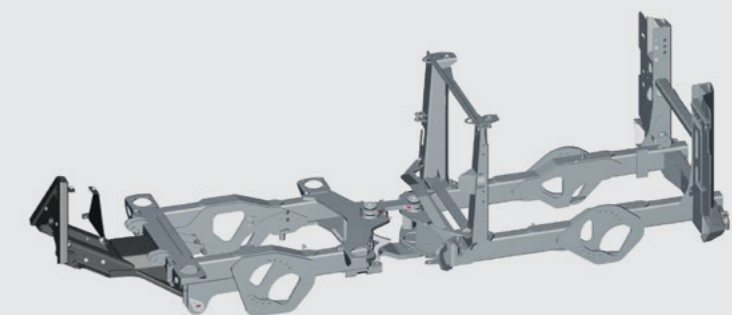

# POWERFUL, CLEAN AND VERY FLEXIBLE.

**Set-up times, engine performance, emissions legislation: the requirements on very different levels and from completely different directions are diverse. Our solutions are too.**

Whether it is local, regional or global: legislators worldwide are tightening the emissions regulations, thus increasing the requirements of drive systems today. We are well-positioned with our 42 HP (31 kW) Yanmar three-cylinder diesel engine with particulate filter. Its exhaust emissions values comply with the requirements of Tier 4 Final - despite an impressive motor rating. Nothing stands in the way of applications in environmental zones and also the budget is reduced considerably with the low fuel consumption.

## CHANGE IN A MATTER OF MINUTES

1

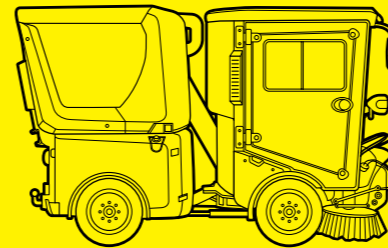

2

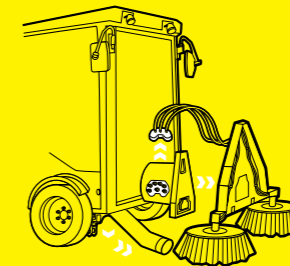

3

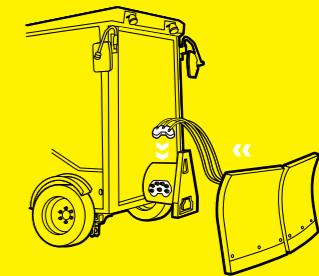

4

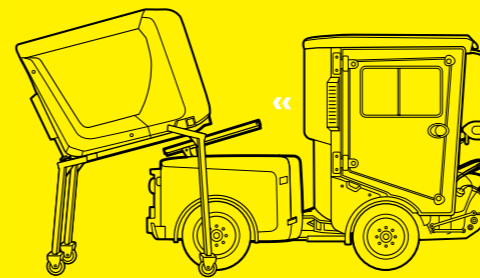

5

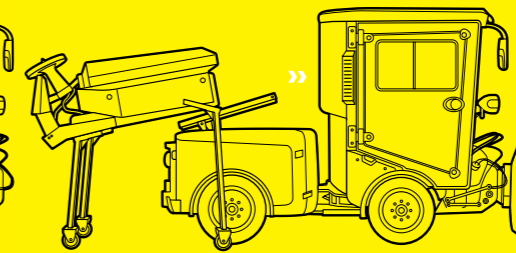

6

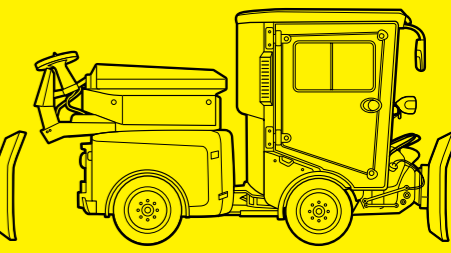

**Our integrated quick-change system for front and rear attachments allows one person to effortlessly change attachments and reduces the set-up times, thus making applications much more flexible.**

**Standard A-frame interface** for the mounting of various front implements allows for maximum flexibility, as both attachments from Kärcher as well as existing machines in the building yard and from diverse manufacturers can be mounted.

**Optional multicoupling system** practically reduces the effort for the operator to zero with lever action. Also the time-consuming and awkward job of connecting and removing individual hydraulic couplings is dispensed with entirely.

**Pressureless function for front and rear attachments** also relieves workshop employees or drivers when changing attachments. Rear attachments are changed easily and without great effort using supporting legs and the hydraulic tilting frame of the machine.

# COMFORT FROM FRONT TO BACK



**Workstation made attractive** We are very proud of the cabs in our municipal machines. The low entry on both sides is already a good start to the working day, there is a feel-good atmosphere in the inside with lots of space, clearly laid-out operating elements and practical equipment details such as opening side windows on both sides, bottle holder, USB charging connections, lockable storage compartment or optional air-suspended seat with integrated document compartment.

The 360° panoramic view boosts safety and the innovative all-round ventilation system ensures an optimal interior climate in summer and winter. An intuitive multifunction display serves for the monitoring and adjustment of machine data and functions. Another 5" (127 mm) display can be installed as an option in conjunction with a suction mouth reversing camera. The MIC 42 is also certified with the AGR quality seal (Aktion gesunder Rücken e.V.) for ergonomics.

**Service and maintenance made easy** High-quality components guarantee long maintenance intervals of around 500 hours. This increases the productivity and reduces the effort in the workshop considerably. If servicing, maintenance or cleaning work are required, we also make it as convenient as possible for you here. All relevant components are quickly accessible without great effort

for cleaning or maintenance tasks. This is also made possible by the foldable side panel, whose single parts can be easily removed without the need for tools. Cleaning the fuel or air-conditioning cooler is also effortless thanks to a clever folding function.

# 01

## WINTER MAINTENANCE

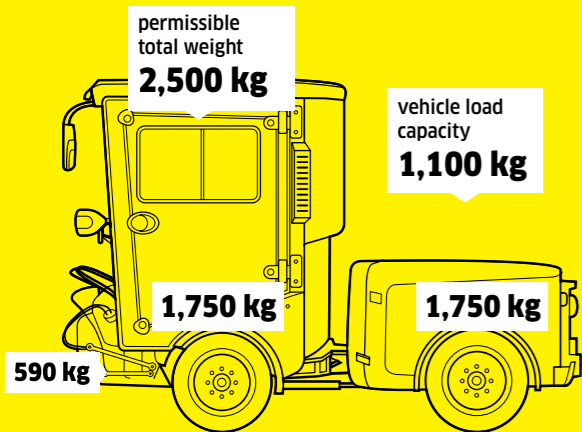

**Maximum flexibility** When the weather isn't as forecasted the MIC 42 has you covered. The MIC 42 can be retrofitted from sweeper to winter service - and vice versa - in a matter of minutes. This saves time and money.

**High compatibility** Extreme applications and the mounting of heavy attachments are easily possible thanks to the high lifting capacity of the front lifter as well as the enormous payloads and axle loads - e.g. for the mounting of a 0.58 cu. yd. (450-litre) semi-mounted spreader. The standard coupling triangle is compatible with Kärcher made attachments and from other attachment manufacturers.

**High-performance hydraulic system** Depending on the respective application, our system offers you 3 hydraulic options (front max. 15.85 gpm (60 l/min), rear max. 10.56 gpm (40 l/min)). By means of proportional control of the hydraulics, front and rear attachments can be controlled directly from the cab, e.g. for optimal spread width control. In addition, there is the option of comfortable spread function independent of the route.



# 02

## SWEEPING

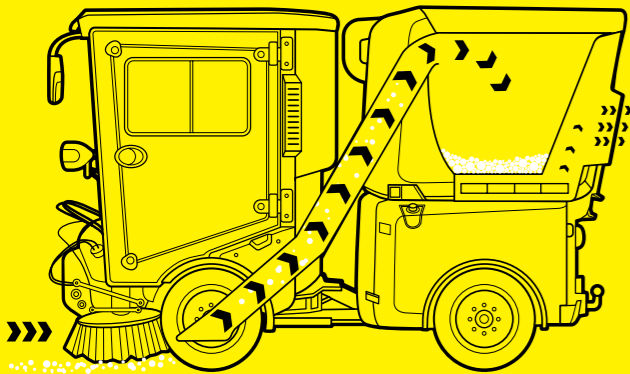

**Intuitive operation. In every detail** Our MIC 42 municipal machine has a - guided two-brush system with individual brush control. Many sweeping parameters are individually adjustable, whereby the brushes themselves can be controlled independently of each other via 2 joysticks - for example, also to move or lift them separately at the side. Collision damage is practically impossible with the protected suction mouth in the wheel contour of the front wheels with automatic coarse dirt flap. The Eco button allows you to immediately restore the last used settings upon restart at the touch of a button, thus saving you time.

**Vacuuming. Reinterpreted** Our suction turbine is made from an innovative composite material, is optimised for aerodynamic efficiency and works very quietly, saving fuel and protecting the drive. The waste is collected in a 1.05 cu. yd. (800-litre) waste container and conveniently emptied in typical standard containers by means of high dump. The process itself can even be controlled directly from the cab. In conjunction with our optional water reclamation system, the container size guarantees long work applications.

**Quick change without tools** Speed is often of the essence in day-to-day work. That's why the suction tube can be quickly removed for cleaning without the need for any tools and practically without any effort. Also the suction mouth is easily and ergonomically installed and removed via the suction mouth rod. A special brush wagon is also available from Kärcher for the time-saving removal and safe storage of the brush system.

**Even more flexibility** With the coupling triangle it is also possible to install the 3rd side brush or a weed brush directly on the mounting of the two-brush system. This allows the removal and pick-up of weeds in just one step - unique in this vehicle class.





# 03

## LANDSCAPING & LAWN CARE

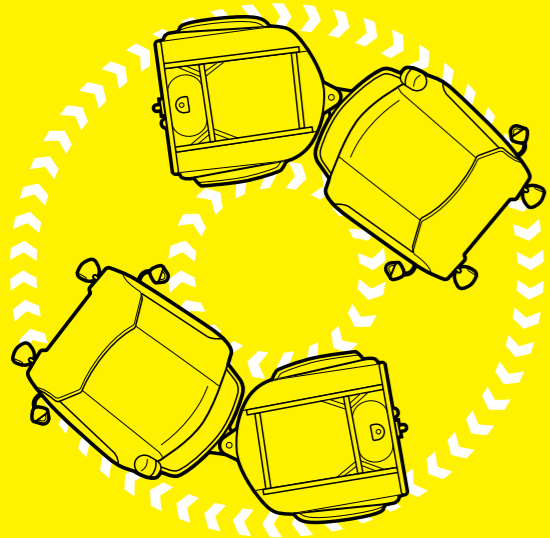

**Maneuverable, comfortable, lawn-friendly** Our MIC 42 municipal machine feels right at home whether it's landscaping overgrown areas or manicuring elegant golf courses. The very low deadweight of only 3,086 pounds (1,400 kilograms) and the low ground contact pressure easily allow the maintenance of delicate lawn areas, whereas the narrow turning circle enables a high degree of maneuverability in places with limited space. Also driving under trees is made possible thanks to the low height of just under 7 feet (2 metres). Thanks to our sophisticated articulated steering, the rear vehicle always drives 100% in the track of the front vehicle, which also helps protect the grass cover. On top of everything, the ride is also comfortable thanks to the long wheelbase.

**For tough applications and high payloads** Also the mounting of large front attachments such as a 4.6 feet (1.40 metre)-wide flail mower or a 5.9 feet (1.80 metre)-wide sickle mower does not pose a problem for our this municipal machine because axle loads, payload and digging force are designed for tough applications and high weight. When mowing, the waste container does not need to be replaced, as it is also suitable for picking up grass cuttings, which is done very efficiently by means of suction.



# 04

## WEED REMOVAL



Number of applications →



**Hot water weed removal and more** Mounted on the MIC 42, our WRS 200 does not require an external power or water supply and can thus also be used in remote locations for mobile, environmentally friendly and effective weed removal with hot water. Even without herbicides, neither the visible plant nor its roots can stand up to the 98°C hot water, whilst the environment and surfaces are protected. Besides the effective removal of weeds, the WRS 200 is also suitable for a variety of other applications, such as mobile high-pressure cleaning, irrigation or the removal of chewing gum.

**Compact design** Our WRS 200 is so compact that even when cornering the vehicle rear remains in the outer contour of the side mirror and also the overall width of the vehicle is not influenced. This not only reduces the risk of getting stuck against house walls or vehicles, but also provides for enormous manoeuvrability. Nothing stands in the way of applications in narrow, confined areas, such as on footpaths.

**Low vehicle centre of gravity** The WRS 200 is designed so that it is located at the rear of the vehicle and the up to 132 gallons (500-litre) water tank sits optimally on the rear trolley and ensures a low vehicle centre of gravity. This enhances the comfort in road traffic and at the same time reduces the risk. The WRS is connected by means of a standard A-frame coupling triangle.

**Logical operating concept** As simple as possible and so logical that operating errors and risks for the operator can be ruled out in principle. This is evident for example in the clear separation of operation and maintenance of the machine. On the left of the machine are the parts associated with maintenance and service and on the right are the operating elements. Temperature setting, pressure control or the switch for the burner are always accessible from the roadside or the path. The operator does not have to stand on the road to operate the machine. Thanks to our clever Easy Operation system a separate display becomes superfluous.

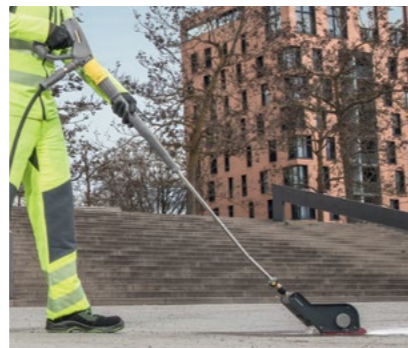

# AS DIVERSE AS YOUR REQUIREMENTS

With our municipal machines we offer you sophisticated, reliable, comfortable, effective and economical machines with which we cover the entire range of municipal tasks and activities. We have the machine and the appropriate implement.



Film

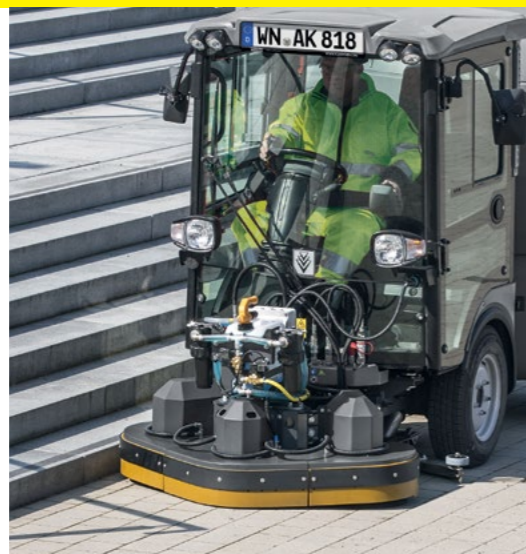

# YOU MANAGE YOUR SUCCESS. WE GIVE YOU THE SUPPORT.

Almost everything can be so much easier when talents are combined. Because it is more successful to pursue objectives together, complement each other and learn from each other. You could call it the principle of progress. We call it Kärcher Services. A promise of partnership. By professionals for professionals.

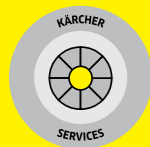

**Kärcher Services:**  
The complete service package from the global leader. And the perfect continuation of the progressive Kärcher system with innovative tools, customised service offers and high-performance software solutions.



**Kärcher Lease - Leasing**  
Customised. Flexible. Safe. We give you the flexibility you need: with leasing and financing models for every requirement.

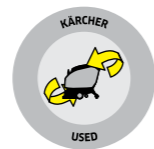

**Kärcher Used - Used machines**  
When used or second-hand is what you need. Starting up? Or simply want to save costs? We have the right used machine for you. Used, generally reconditioned, good and affordable. Offers are constantly changing. Ask us.



**Kärcher Service - Customer Service**  
Service means trust. At all times. Services you actually need. Fast response for maximum availability. Maximum value retention and compliance with all statutory requirements.



**Kärcher Rent - Renting**  
Just the machine you need. Rent instead of buying. And get more: expertise and Kärcher Full Service in one package.



**Kärcher Maintain - Service packages**  
Every service package is tailored precisely to a defined requirement. The range of services includes inspections as part of prescribed safety tests, timely maintenance and flat-rate full service.

Please contact us for more information:

### **USA**

Kärcher Municipal North America Corp  
3 Allied Drive | Suite 303  
Dedham, MA  
02026

Phone +1 844. 332. 3200

Fax +1 613. 443. 9600

[www.kaerchermunicipal-na.com](http://www.kaerchermunicipal-na.com)

### **Canada**

Kärcher Municipal North America Inc  
100 Bay Street  
Embrun, Ontario  
K0A 1W1

Phone +1 613. 443. 3200

Fax +1 613. 443. 9600

[www.kaerchermunicipal-na.com](http://www.kaerchermunicipal-na.com)